

PURPOSE/APPLICATION

To provide guidance on the use and care of various wrenches, they come in many types and sizes. This practice is intended to provide some best practices for the use and care of wrenches. Each time a wrench is used it can create a unique situation and should be evaluated using the HIAC process before starting the task.

PPE

- Strike minimum requirements
- Hand Protection

TRAINING

- On the job instruction
- Review of manufactures instructions

HAZARD SOURCES & CONCERNS

- Personal injury
- Slipping wrench
- Pinch/crush points
- Electrical shocks



General Do's and Don'ts

THE DO's:

- **DO** Inspect the wrench to ensure it is not damaged or defective in any way
- **DO** Use a wrench that pulls in a straight and clean manner
- **DO** Use the proper size wrench for the job
- **DO** Place/keep/store tools in a safe & secure place
- **DO** Hold the tool close to the body and do not overreach
- **DO** Keep good balance and proper footing at all times to better control the tool, especially in response to unexpected situations (wrench slip, broken nut, etc.)
- **DO** Secure work with clamps or securing devices, freeing hands to operate the tool
- **DO** Keep tools clean and free from dirt, oil and other contaminants that can hinder grip and performance
- **DO** Use mechanical advantage tools, not snipes or cheater bars. Examples: torque wrenches, torque multipliers, tubular wrenches, socket/breaker bars, extending ratchet, 48-inch or larger pipe wrenches, compound leverage pipe wrenches, chain wrenches
- **DO** Use tool lanyards if working at heights with workers below

THE DON'Ts

- **DON'T** Pull wrenches towards your face
- **DON'T** Use worn, cracked or deformed wrenches. Replace them immediately to avoid injury
- **DON'T** Attempt to straighten a bent wrench. Doing so will only further weaken it
- **DON'T** Substitute slip-point pliers for a wrench
- **DON'T** Use a hammer with a wrench unless the wrench was specifically designed for that purpose
- **DON'T** Use hand tools to back up hydraulic or pneumatic tools. Use the original equipment manufacturer (OEM) supplied backing or reaction arm
- **DON'T** Put hands or fingers into pinch points when using a wrench or socket/driver
- **DON'T** Use with your wrist bent, tools should be designed to allow wrist to stay straight
- **DON'T** Throw or toss tools. Hand them, handle first, directly to other workers
- **DON'T** Carry tools in a way that interferes with using both hands on a ladder
- **DON'T** Use snipes, lever bars, cheater bars



Proper use and care of wrenches:

Wrenches are designed for holding and turning nuts, bolts, cap screws, plugs and various threaded parts. Quality wrenches, regardless of their type, are designed to keep leverage and intended load in safe balance. Standard wrench types are available with both American standard inch and metric openings. Special wrenches are also available for servicing and overhaul of certain equipment.

Different types of wrenches are of different strengths and are designed for different purposes, such as for wrenching high-strength fasteners. Box end and socket type wrenches, because they surround the fastener head, are the strongest types of wrenches and have less chance of slipping off the fastener. Open end, flare nut and adjustable wrenches are not as strong as the corresponding sizes of box or socket wrenches because they do not surround the fastener head, and are not intended for heavy loads, such as breaking loose frozen fasteners.

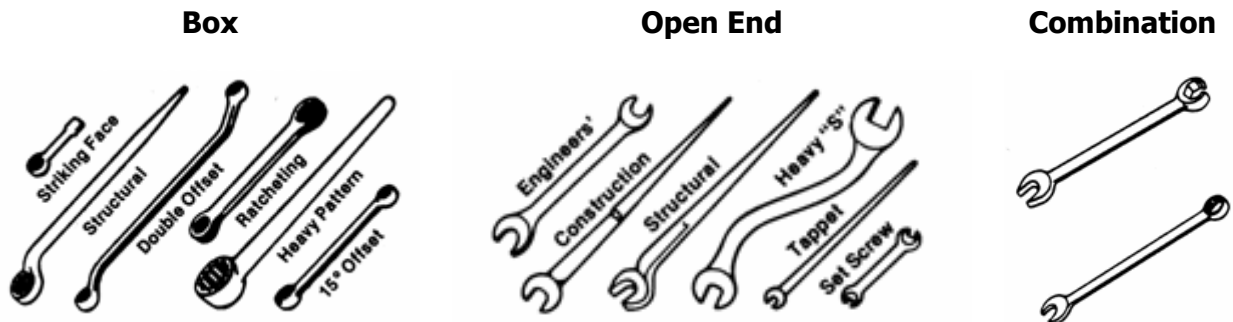

THE DO's:

- **DO** Select a wrench whose opening exactly fits the nut. If the wrench is not exactly the correct size for the fastener, it may damage the corners of the fastener, slip or break
- **DO** Use only inch wrenches for inch fasteners and metric sizes for metric fasteners
- **DO** Pull on a wrench handle and adjust your stance to prevent a fall if sudden release occurs
- **DO** Free a "frozen" nut or bolt by using a striking-face box wrench or a heavy-duty box or socket wrench

- **DO** Use penetrating oil to the fastener threads beforehand, this will reduce the breaking force needed
- **DO** Use a torque wrench, it will permit tightening to the exact torque required
- **DO** Use thread lubrication, it not only reduces the friction during tightening, it can also decrease the chance of bolt failure during installation and increases bolt life too
- **DO** Disconnect the power before working on electrical equipment or devices

THE DON'Ts

- **DON'T** Modify wrenches/tools
- **DON'T** Use a pipe extension or other form of "cheater" to increase the leverage of any wrench
- **DON'T** Double wrench
- **DON'T** Cock/angle a combination wrench. Be sure the nut or bolt head is fully engaged
- **DON'T** Over- or under-torque. A torque wrench will permit tightening to the exact torque required
- **DON'T** Expose any wrench to excessive heat that may change the hardness and metal structure and ruin the tool
- **DON'T** Push unless you hold the tool with your palm open, and brace yourself against a fall
- **DON'T** Grind a wrench, even as a means of identification
- **DON'T** Use a wrench that has been damaged by being bent, cracked, or severely worn
- **DON'T** Depend on an electrically insulated tool to protect you from electricity. Ordinary plastic-coated handles are designed for comfort and provide no electrical insulation. Other tools, such as insulated and insulating, that have high-dielectric insulation are so identified. The high-dielectric insulation is intended only as secondary protection and for use by trained personnel.



Adjustable Wrenches (Crescent Wrench)

An adjustable wrench has one fixed jaw and one adjustable jaw which allows you to use it on a wide variety of fastener sizes. The jaws are typically smooth and flat and designed for gripping square and hex nuts. The head of a crescent wrench is usually angled at 22 1/2 degrees to the handle so that the wrench can be flipped over to provide two different gripping positions in tight spaces. While a crescent wrench is designed so that you can apply pressure on both the fixed and movable jaws, ideally the bulk of your work should be done so that pressure is only applied on the stronger, fixed jaw. Too much pressure on the weaker, adjustable jaw can cause the wrench to break and you to bark a knuckle. When placing the wrench on your nut, the adjustable jaw should be located on the side towards which the rotation is to be performed. This puts the pressure on the fixed jaw.

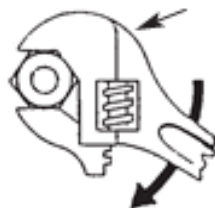

Proper jaw position to tighten



Improper jaw position to tighten

THE DO's:

- **DO** Use adjustable wrenches for light duty work

THE DON'Ts

- **DON'T** Use adjustable wrenches to take the place of standard open-end, box or socket wrenches

Hammer Wrenches

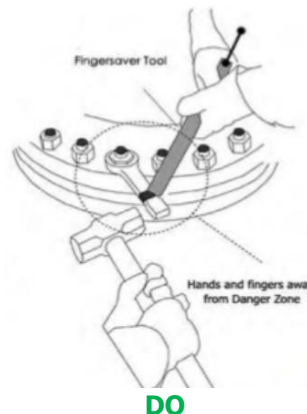
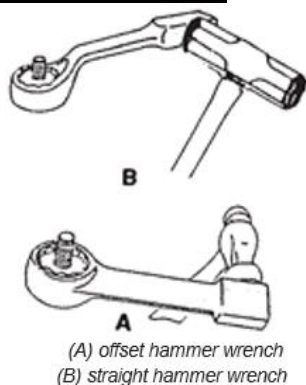

THE DO's:

- **DO** Use hammer wrenches when great force is required to release nuts and bolts
- **DO** Ensure safety glasses are worn, chipping is highly likely
- **DO** Use brass hammer wrenches in potentially flammable/explosive environments

THE DON'Ts

- **DON'T** Hold hammer wrenches with your hands
- **DON'T** Use hammer wrenches in potentially flammable/explosive environments, none sparking versions are available

Sockets, handles and attachments

There are two common types of sockets – hand and impact. Each is different in design and hardness. Hand sockets usually have a bright finish but may have a black finish. Impact sockets have a black finish and usually have thicker walls. Sockets are made in regular length and deep length. Openings may be 12, 8, or 6-point or square. Spark plug sockets have rubber inserts or other devices to hold the plug. Universal joint sockets are also available.

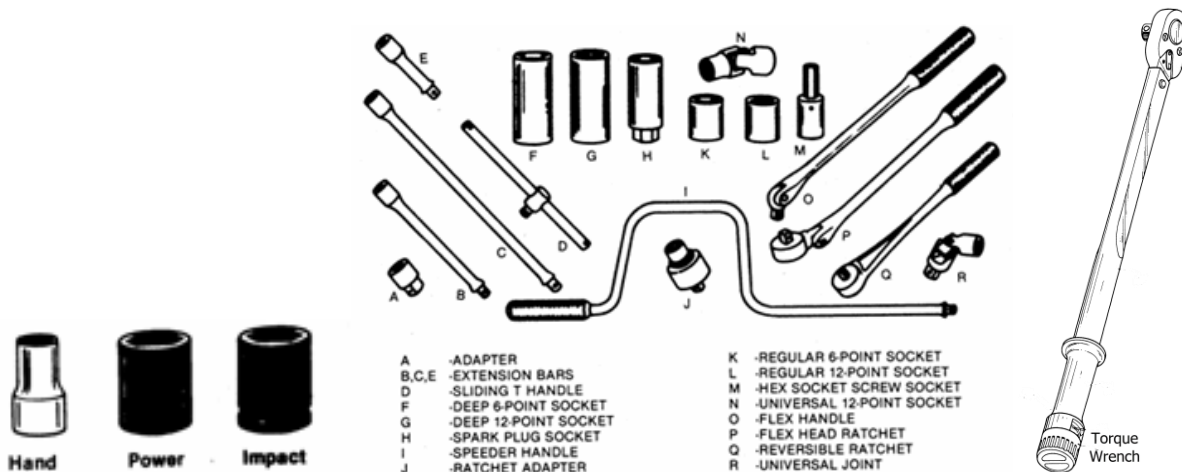

Proper Use and Care of Sockets and Socket Wrenches

THE DO's:

- **DO** Select the right size and type of socket to fit the nut (inch/metric)
- **DO** Select the largest possible drive size – many sockets are available with smaller drive sizes than should be used at high load. They may be used for run-up (pre-tightening) or other low-load applications
- **DO** Select the appropriate handle
- **DO** Periodically clean and inspect handles, sockets and attachments. Many manufacturers supply parts, repair kits and instructions for servicing their ratchet wrenches and handles. Repairs to the handles or ratcheting mechanism should be made as per manufacturer's specifications
- **DO** Remember that when adapting "down" (big handle, small socket), you build up tremendous torque potential and risk breaking the socket
- **DO** Remember that when adapting "up" (small handle, big socket), there is a risk of applying too much force to the handle and it may break
- **DO** Use a pin and retaining ring with impact sockets on an impact gun
- **DO** Set torque wrenches to the correct setting and use the lock screw
- **Do** Use calibrated torque wrenches

THE DON'Ts

- **DON'T** Increase the leverage of a wrench handle by use of a pipe or other form of cheater on the wrench handle
- **DON'T** Use hand sockets on power drive or impact wrenches
- **DON'T** Attempt to repair sockets
- **DON'T** Use sockets or attachments with any signs of cracking
- **DON'T** Use any socket with rounded or damaged wrench openings, or with worn or deformed drive ends
- **DON'T** Go past the first click or torque setting on a torque wrench while tightening

Pipe Wrenches

Pipe tools are made in various shapes and sizes and for many uses. Always use the correct tool for the job.

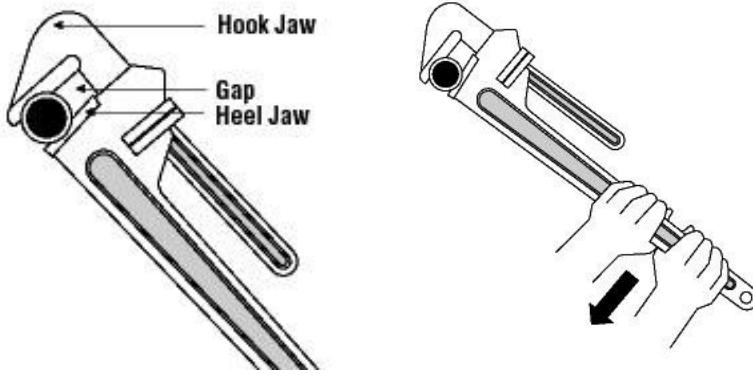

Suggested Pipe Wrench Size Reference	
Wrench	Pipe Dia.
6"	1/8" - 1/2"
8"	1/4" - 3/4"
10"	1/4" - 1"
12"	1/2" - 1 1/2"
14"	1/2" - 1 1/2"
18"	1" - 2"
24"	1 1/2" - 2 1/2"
36"	2" - 3 1/2"
48"	3" - 5"
60"	3" - 8"

THE DO's:

- **DO** Pay special attention to the jaws when inspecting pipe wrenches. Make sure they are still sharp or they can cause slippage that may lead to injury
- **DO** Select a pipe wrench with sufficient capacity and leverage to do the job
- **DO** Use a pipe wrench to turn or hold a pipe
- **DO** Adjust the pipe wrench grip to maintain a gap between the back of the hook jaw and the pipe. This concentrates the pressure at the jaw teeth, producing the maximum gripping force. It also aids the ratcheting action
- **DO** Face a pipe wrench forward. Turn wrench so pressure is against heel jaw
- **DO** Inspect pipe wrenches periodically for worn or unsafe parts and replace them (e.g., check for worn threads on the adjustment ring and movable jaw)
- **DO** Pull, rather than push on the pipe wrench handle. Maintain a proper stance with feet firmly placed to hold your balance

THE DON'Ts

- **DON'T** Use a pipe wrench as a hammer, or strike a pipe wrench with a hammer
- **DON'T** Use pipe wrenches on nuts and bolts
- **DON'T** Use a pipe extender for extra leverage. Get a larger pipe wrench
- **DON'T** Use the wrench if the nut is located at the very end of the hook jaw
- **DON'T** Use on hard, square or hexagonal material; it is designed to turn pipe or soft round stock. Wrench may slip on hardened material or the teeth may chip when used on hex or square stock
- **DON'T** Apply a side load to the handle. Putting a strain on the wrench in a direction other than it was designed for can result in a broken housing or twisted handle
- **DON'T** Use in conjunction with a power drive, threading machine or any mechanical/hydraulic device to make or break fittings. Use of a power drive, threading machine/hydraulic device to apply force to the handle of a pipe wrench can result in wrench failure and/or serious personal injury

Developed by:	1. Rhys Cooper	2. Todd Penney	Date: Sept 26, 2017
	3. Brian McConnell	4. Christy Giberson	
Revised by:	Todd Penney		March 21, 2019
Approved by:	1. HSE Committee		March 22, 2019