

PURPOSE/APPLICATION

To provide guidance on setting up and rolling spools. Spools can be welded using several different methods and setups. This practice is intended to provide some best practices for the setup of spools. Each spool presents unique challenges and should be evaluated using the HIAC process before starting the task.

PPE

- Canadian Plains minimum requirements
- Safety glasses and welding shield
- Respiratory protection (as required)
- Hearing protection

TRAINING

- On the job instruction from a Canadian Plains supervisor
- Review of the manufacturer’s specifications

HAZARDS SOURCES & CONCERNS

- Personal injury
- Property damage
- Falling spools
- Flying debris
- Noise levels
- Suspended loads
- Rotating parts, pipe
- Electrical



LOADING SPOOLS INTO CHUCKS:



Chuck on Hand Roller



Chuck on Positioner

Different types of chucks are used in several welding procedures, including most types of wheels and positioners. The following are best practices that apply to all setups involving chucks.

THE DO's

DO Set up the pipe inside the chuck and tighten the teeth on the outside of the pipe

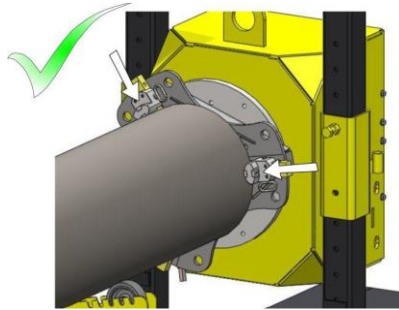

- DO** Check that the pipe is level to the chuck. Pipe that is not level to the chuck may become loose during the rolling process
- DO** Make sure that the chuck is tight; tighten the chuck at all tightening positions
- DO** Tighten the spool into the chuck, roll the spool 90°, check that it is still level, and tighten it again
- DO** Check that the chuck is tight throughout the welding process; if the load is even slightly unbalanced, it may come loose over time
- DO** Mark the position of the chuck on the pipe with a paint marker. This will allow for easy visual identification of pipe moving out of the chuck:



DO Consider welding the spool into the chuck for additional securement (if allowed by client and Canadian Plains Quality Control procedures)

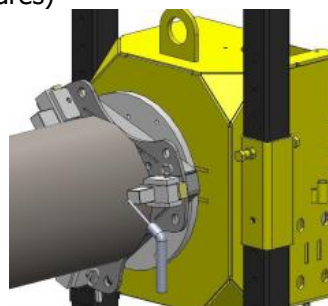

- DO** Check welds for signs of cracking throughout the rolling process
- DO** Load spools so that it puts as little weight on the chuck as possible. This is done using stands or other systems to support the pipe
- DO** Support the spool with at least two stands whenever possible
- DO** Set the first stand as close to the chuck as possible:

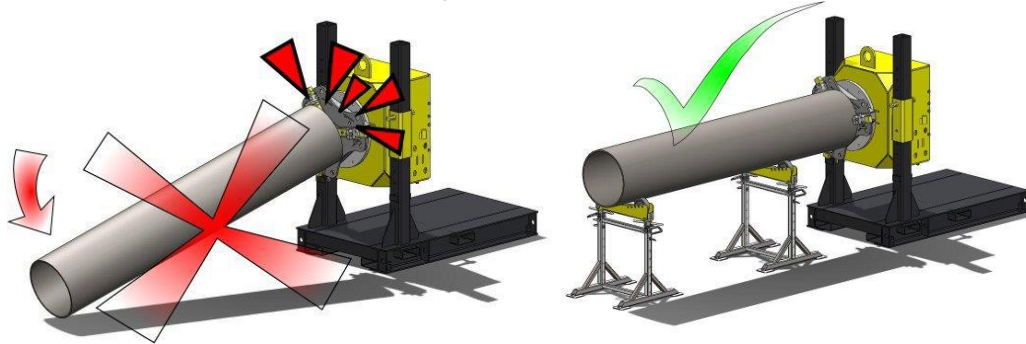

- DO** Calculate the load being put on the chuck. It is important to check that the load does not exceed the manufacturer's specifications
- DO** If you can only use one stand, position the stand just past the center of the spool (away from the positioner) to help balance the load and reduce the load on the chuck
- DO** Use roller heads when rolling spools
- DO** Utilize counterweights where required to ensure the pipe rolls smoothly



Saw Horse Roller Head Stand



Roller Head

- DO** Mark the locations of the stands on the spool with a paint marker (this allows for visual identification of movement in the stands)



Mark the Stand Position on the Pipe

- DO** Double check that stands are level and balanced. Even small movement in the spool can lead to it "walking" out of the stands or the chuck
- DO** Position your body to the side of the load
- DO** Perform a test roll with other workers monitoring the clearance before starting to weld
- DO** Set up exclusion zones around all work areas when rolling pipe
- DO** Be sure the tacks are strong enough to hold the weight of the spool during the rolling process. Check the welds throughout the process for signs of cracking or weakening
- DO** Check that stands manufactured with pins have them in place prior to their being loaded
- DO** Leave some slag on the tacks; slag will crack earlier and can give you some advanced warning that the tacks are popping
- DO** Warn all workers in the area before starting to roll the spool
- DO** Be sure that all pipe stands and heads are rated for the load they are supporting
- DO** Weld your root and hot pass between all tacks before cutting any tacks

THE DON'Ts

- DON'T** Walk under a spool. Even small spools falling from a chuck can cause serious injury or death
- DON'T** Setup a spool with the teeth inside the pipe. As you weld, the pipe will heat and expand

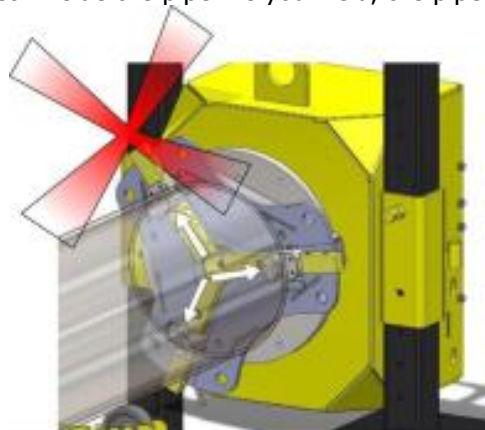

- DON'T** Store material around the spool
- DON'T** Roll spools in V-top rollers



V-Top Heads not to be used for Pipe Rolling

USE OF GRABBERS/JIGS:

Some welds will require the use of an elbow/flange grabber or a Jig to roll. The same procedures as loading a spool apply when loading a grabber into a chuck. The use of a grabber or jig also requires some additional measures.



Elbow Grabber



Flange Grabber



Jig

THE DO's:

- DO** Attach the grabber so that the weight of the spool is balanced when it rolls
- DO** Use a grabber that fits all the way into the chuck (if the grabber is too large for the chuck, a larger chuck should be selected):



Pipe Inside the Chuck



Pipe Only in the Teeth

- DO** Perform a few test rolls and recheck the grabber to verify it is still level and tight
- DO** Check the chain grip, U bolt, or nut every few turns to make sure it stays tight
- DO** Replace nuts frequently; always check the threads before use. Nuts can easily strip both on the threads and on the outside
- DO** Use enough bolts (of the proper size) in a flange grabber to prevent movement and to secure the load
- DO** Consider welding pipe into the grabber where it is permitted by QC specifications (always keep the weld within the bevel area)



Welds directly on the jig can help keep it from spinning in the chuck

USE OF POSITIONERS



The use of mechanical welding positioners provides an advantage with heavy pipe. The worker does not need to extend any physical force to move the pipe, and the worker can generally pick their body position. Use of positioners also presents unique hazards, and the risk must be assessed before starting work. As the worker is not rotating the load, it is harder to identify the early signs of an unbalanced load. If the hazard to the welder cannot be reduced to low risk (using Canadian Plains’s HIAC Risk Matrix), then another method (power rollers, position welding) should be selected.

THE DO’s:

DO Set up the ground clamp from the welder to the manufacturer’s specified grounding location

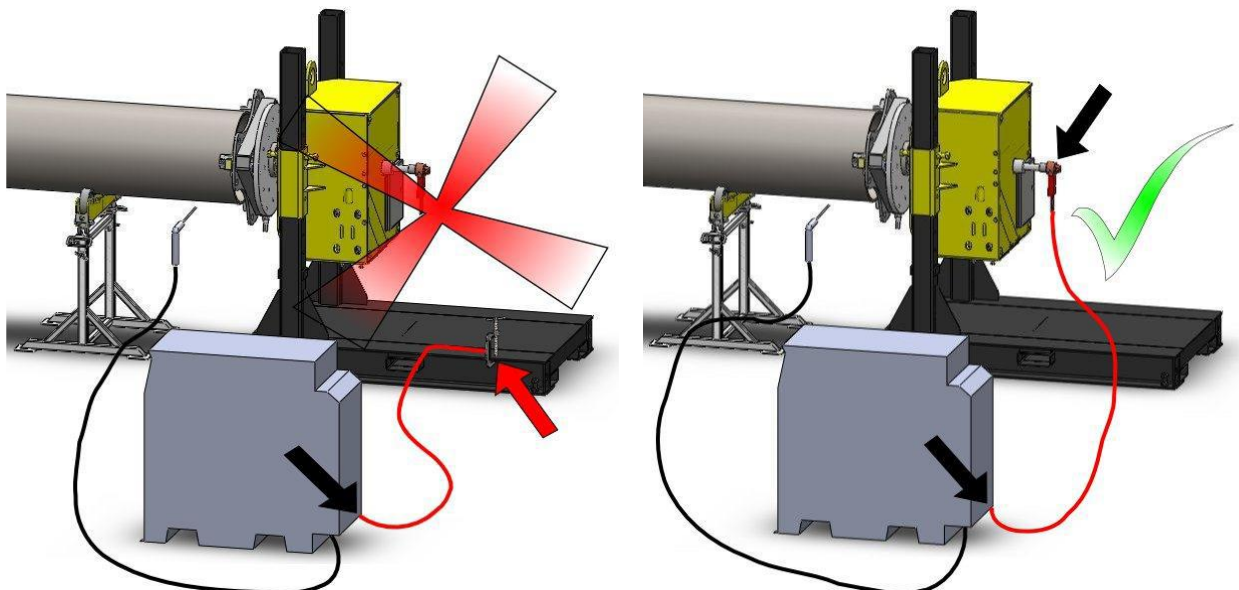

- DO** Make sure the spool is secure in the chuck, since the worker will not be able to feel if the load becomes unbalanced
- DO** Counter-balance properly (see counterbalancing section of SWP)
- DO** Flag off the areas where pups and counterweights will roll
- DO** Ensure that no other workers enter the area during fabrication
- DO** Consider removing the chuck entirely and bolting the flange directly to the face of the positioner
- DO** Consider (if allowed under the manufacturer's specification) welding nuts to the face of the positioner so bolts can be used as an additional method of securement

THE DON'Ts

- DON'T** Ground the welder to the frame of the positioner
- DON'T** Start rolling until all other workers are clear of the area

COUNTERBALANCING

Counterbalancing is extremely important on any spool that is not straight. If the load is not balanced, the vibration in the roll can cause the spool to fall out of the chuck, or cause a stand to "walk" out from under the pipe, potentially resulting in injury or property damage

THE DO's:

- DO** Attach the counterweight to the load on the opposite side of the spool as the off-center weight

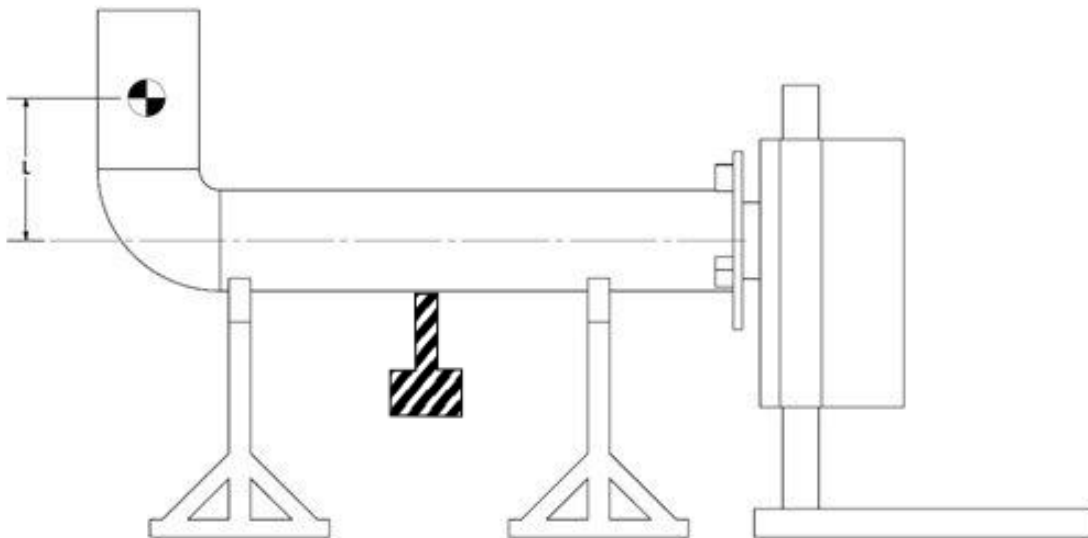

- DO** Check that counterweights are properly secured to the load; a counterweight coming free will unbalance the load
- DO** Perform test rolls to be sure the spool will roll evenly. If the load is not balanced, there is a much higher chance the load will work its way out of the positioner
- DO** Check your counterweight throughout the welding process, verify it is not coming loose, and that welds are not cracking
- DO** Flag off the area under counterweights. No individuals are permitted to enter this area
- DO** Perform a test roll with another worker watching the rotation to be sure the load will clear the ground
- DO** Ensure rolls are square so they will walk
- DO** Strategically place power rollers to avoid any interference with branch connection cutouts and attachments

POWER ROLLERS



Power Roller with Stand



Power Rollers

When setting up power rollers, it is very important that the ground be level and the load is being spread evenly between the rollers.

THE DO's:

- DO** Check that the center of mass on the spool is even. If there are attachments, it must be counterbalanced before rolling
- DO** Break the loads into thirds to get an indication of where the stands should be positioned
- DO** Check that when the rollers are raised higher to accommodate attachments, the stands are fully supported and that the supports are able to handle the weight of both the stands and the load

Developed by:	1. <u>Brian McConnell</u>	2. <u>Jon Greeves</u>	Date: <u>May 2016</u>
	3. <u>Nick Oldring</u>	4. <u>Travis George</u>	
	5. <u>Lockie Johnston</u>		
Revised by:	1. <u>Brian McConnell</u>	2. <u>Sonny Baceda</u>	Date: <u>February 23, 2026</u>
	3. <u>Trevor Shelton</u>	4. <u>Chad Palazeti</u>	
	5. <u>Chad Sewall</u>	6. <u>Rory Jordan</u>	
	7. <u>Dylan Dressler</u>	8. <u>Bryan Franka</u>	
	9. <u>Hank Sutmoller</u>		
Approved by:	1. <u>HSE Committee</u>		Date: <u>May 7, 2026</u>
